

Schottky-Barrier Diode(SBD) Single

Device Type	Features	Page	VRRM	IF	Package
CB803-03	SCHOTTKY BARRIER DIODE (30V/2.0A)	3	30V max	2.0A	Lead-3
ERA81-004	SCHOTTKY BARRIER DIODE (40V/1A)	3	40V max	1.0A max	Lead-2
ERA82-004	SCHOTTKY BARRIER DIODE (40V/0.6A)	3	40V max	0.6A max	Lead-1
ERA83-004	SCHOTTKY BARRIER DIODE (40V/1A)	3	40V max	1.0A max	Lead-1
ERA83-006	SCHOTTKY BARRIER DIODE (60V/1A)	3	60V max	1.0A max	Lead-1
ERA84-009	SCHOTTKY BARRIER DIODE (90V/1A)	3	90V max	1.0A max	Lead-2
ERA85-009	SCHOTTKY BARRIER DIODE (90V/1A)	3	90V max	1.0A max	Lead-1
ERB81-004	SCHOTTKY BARRIER DIODE (40V/2.0A)	3	40V max	2.0A max	Lead-4
ERB83-004	SCHOTTKY BARRIER DIODE (40V/2.0A)	3	40V max	2.0A max	Lead-3
ERB83-006	SCHOTTKY BARRIER DIODE (60V/2A)	3	60V max	2.0A max	Lead-3
ERB84-009	SCHOTTKY BARRIER DIODE (90V/2A)	3	90V max	2.0A max	Lead-4
ERC62-004	SCHOTTKY BARRIER DIODE (45V/10A)	3	45V max	10A max	TO-220AB(FE,JEDEC)/ SC-46(EIAJ)
ERC80-004	SCHOTTKY BARRIER DIODE (40V/5A)	3	40V max	5.0A max	TO-220AB(FE,JEDEC)/ SC-46(EIAJ)
ERC81-004	SCHOTTKY BARRIER DIODE (40V/3.0A)	3	40V max	3.0A max	Lead-7
ERC81-006	SCHOTTKY BARRIER DIODE (60V/3A)	3	60V max	3.0A max	Lead-7
ERC81S-004	SCHOTTKY BARRIER DIODE	3	40V max	5.0A max	Lead-7
ERC84-009	SCHOTTKY BARRIER DIODE (90V/3A)	3	90V max	3.0A max	Lead-7

SCHOTTKY BARRIER DIODE

Outline drawings, mm

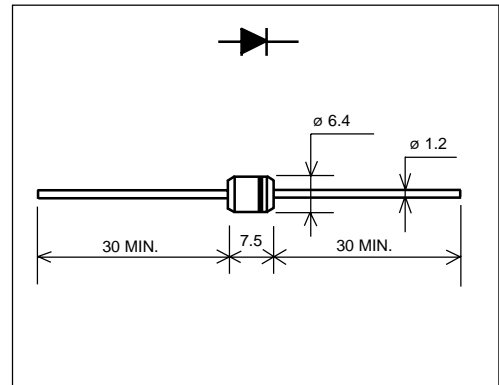

Features

- Low V_F
- Super high speed switching
- High reliability by planer design

Applications

- High speed power switching

Marking

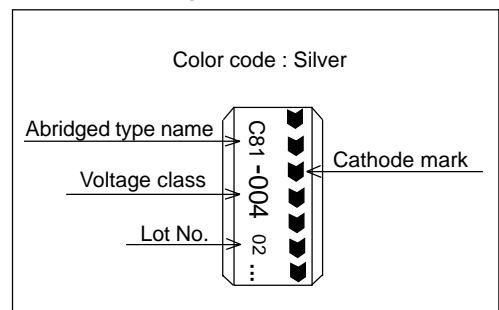

Maximum ratings and characteristics

- Absolute maximum ratings

Item	Symbol	Conditions	Rating	Unit
Repetitive peak reverse voltage	V_{RRM}		40	V
Average forward current	$I_{F(AV)}$	Square wave, duty=1/2 $T_I=130^{\circ}C$	3.0	A
Surge current	I_{FSM}	Sine wave 10ms	120	A
Operating junction temperature	T_j		-40 to +150	$^{\circ}C$
Storage temperature	T_{stg}		-40 to +150	$^{\circ}C$

- Electrical characteristics ($T_a=25^{\circ}C$ Unless otherwise specified)

Item	Symbol	Conditions	Max.	Unit
Forward voltage drop	V_{FM}	$I_{FM}=3.0A$	0.55	V
Reverse current	I_{RRM}	$V_R=V_{RRM}$	5.0	mA